



Mechanical and muscle powered wheelchairs

Safety and general handling information



MEYRA®
We move people.

Contents

Introduction	4
General safety information	5
Driving	7
Driver training	8
Supplemental user information	9
Wheelchair and car	13
Brakes	14
Pressure Brake	15
Drum Brake	16
Drum brake for attendant	16
Weight loading	17
Tyres	18
Removable drive wheels	19
Height-adjustable leg supports	20
Footplates	20
Back support with angle adjustment	21
Seat angle adjustment	21
Handrims	22
Head support	22
Walking aid holder	22
Retaining strap	23
Retaining strap with velcro fastener	23
Retaining strap with buckle	24
Therapy table	25
Mount the therapy table	25
Transfer out of the wheelchair	26
Reaching for objects	27
Propelling the wheelchair	29
Driving through narrow passages	29
Driving on falling, rising or transverse gradients	30
Uphill driving	30
Downhill driving	32
Driving transverse to the inclination	33

Turning during uphill/downhill driving	33
Anti-tip castors and wheelbase adapter	34
Crossing obstacles	35
Wheelchair folding/unfolding/carrying	39
Folding the wheelchair	39
Carrying the wheelchair	39
Unfolding the wheelchair	39
Transport in motor vehicles or with conveyors	40
Transport safety of the empty wheelchair	41
Transport in vehicles	42
Transport of people inside a motor vehicle	42
Driving on ramps, elevators and lifting platforms	43
Ramps and lifting platforms	44
Transport in public methods of transportation	46
Parking space	46
User information	46
Driving on public highways	47
Road and weather conditions	48
Accompanying person	49
Additional information for folding wheelchairs with lever drive	49
Auxiliary drives	49
Service	50
Information for the specialist dealer	50
Information for extended pauses of use	50
Tyres	51
Cleaning and maintenance	51
Upholstery and covers	52
Chassis	52
Disinfection	53
Reinstallation	53
Repairs	53
Customer Service	53
Spare parts	54
Disposal	54
Notes	55

INTRODUCTION

This safety and general handling information for < *Mechanical and muscle powered wheelchairs* > has originated from the experiences of wheelchair users, accompanying persons and safety specialists from our company and have been compiled for you in an easy to understand picture and text format. Acquire the experience of this group of experts with attentive reading. You only invest a small amount of time but gain a high level of safety; for yourself and other people.

You should know the following:

- This accompanying document completes the operating manual for your wheelchair.
 - If the wheelchair model shown in the illustrations is not identical to yours, you can analogically apply the described circumstances to your own model.
 - Read and observe the operating manual before first use of the wheelchair in order to master your wheelchair safely and to maintain its flawless function.
 - The design of your wheelchair ensures a high level of operational safety. Despite this, you must be familiar with possible danger situations during the use and know how to deal with them.
 - Depending on the degree of your disability—certain driving manoeuvres serving the safety may not be possible or only partly possible—despite the adaptation of the wheelchair to the disability.
-  Drive especially carefully in such cases. This serves your own safety.
- This document also incorporates special control options, provided they re-

quire explanation for safe handling. The equipment fitted to your wheelchair can deviate from that described in the information text or shown in the illustrations because the scope of supply is determined by the individual wheelchair purchase.

- In case your wheelchair changes user, these safety and general handling instructions < *Mechanical and muscle powered wheelchairs* > are to be handed over together with the operating manual and wheelchair!
- Our implemented assembly groups and components fulfil the demands of the norms of correspondence acc. to EN 12183 for durability against flaming.

GENERAL SAFETY INFORMATION

Only use your wheelchair in such a fashion as it is designed for by its specification/operation in the operating manual.

Example [1]:

- Do not drive into water with your wheelchair.
- For storage or when entering or exiting the wheelchair select a surface that is as horizontal as possible, level and firm. Secure the wheelchair against accidental movement. – E.g. operate the parking brakes [2].
- Do not park an unused wheelchair freely accessible in order to prevent an unauthorised use, misuse or vandalism.
- Never leave children or adolescents in wheelchairs unsupervised.
- Do not rest your legs on furniture or other items. – Leaning backwards then changes the centre of gravity and increases the risk of tipping over.
 - ☞ Use height-adjustable leg supports.
- Do not insert fingers into open frame tubes (for example after removing the leg supports). – Danger of injury!
- A stable sitting position is to kept while using the wheelchair, even when not in motion and especially on hills and slopes. – Danger of accident!
- In a safe sitting position the back of the user lies directly on the back support belt/-cushion and the hip of the user is at the back end of the seat belt/-cushion.

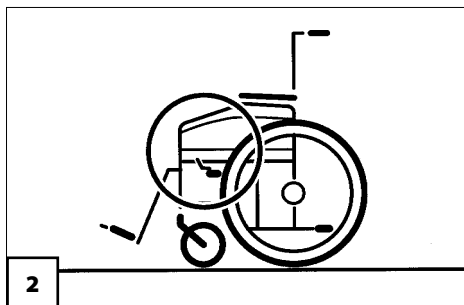
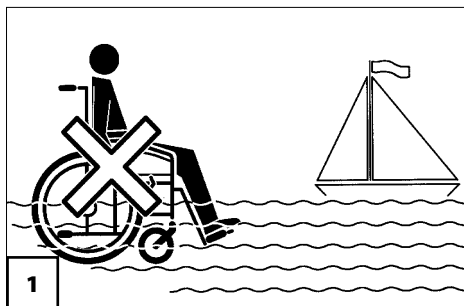

- A back support reclined to the rear or a seat raised at the front generally bears the risk of tilting over in drive mode.
- Observe that by taking along objects, attaching or removing accessories/components, the balance point relations and thus the driving behaviour can change in a safety relevant fashion.
- Never reach into the swivel area of the components when operating adjustment devices, e.g. back support or leg supports. There is a danger of injury through squashing.

Therefore:

- ☞ Place your free hand on the arm support.
- ☞ Place your feet onto the footplates.
- ☞ Inform the helper about the possible dangers of injury.

- Existing manual adjustments are to be adjusted for the drive mode in such a fashion that a secure handling of the wheelchair is warranted.
- Make sure that objects transported on your wheelchair do not restrict or endanger the handling of the wheelchair.
- Do you have sufficient support strength, in order to remain safely seated in the wheelchair in critical situations (e.g. when braking, in curves, when overcoming obstacles)?
- A fastened retaining strap can provide you with sufficient safety.
- Keep well clear of rail grooves, rails and gully covers or similar sources of danger. If not possible, cross such obstacles at a right-angle (90°).
- Do not undertake journeys alone if possible so that you can always have the assistance of a helper in problem situations.
- Do not throw or drop parts belonging to the wheelchair! – Removable parts such as arm supports and leg supports should be handled correctly. Only this can guarantee their function.
- Removable parts, e.g. arm supports and leg supports, must be checked for correct locking before the start of each drive. – Drive wheels with defective linchpin (quick-fit) axles can detach from the wheelchair during the drive.
- Apart from the chassis, the frame and all bowden cables should be checked for damage after a collision with an obstacle. - With visual and / or audible damage immediately call upon a specialist workshop for repair.
- To prevent damages due to corrosion do not use or store the wheelchair in damp rooms.
- Exposure to direct sunlight can cause seat covers/upholstery, arm support pads, leg supports and handles to heat up to over 41 °C. – Contact with exposed skin can result in injury! Prevent such heating by parking the wheelchair in a shaded area.
- By adding on or removing accessories/components the dimensions and weight of the wheelchair change which can affect the driving behaviour.

DRIVING

The fine tuning to optimise the driving behaviour to the personal situation is to be done by your specialist dealer or therapist.

Attention:

- ! Drive with extreme caution during the first trips!
- Applying a safety belt prevents falling out toward the front.
- In order to raise the backward tilting stability supporting wheels can be mounted later on.
- When propelling the wheelchair over the tyre there is a risk of injury in the area of the pressure brake.
- 🔧 By adding on or removing accessories/components the dimensions and weight of the wheelchair change which can affect the driving behaviour.

🔧 Note:

Ask your specialist dealer about:

- all possible driving behaviour peculiarities of your wheelchair in order to exclude possible danger situations
- the variations and adjustment possibilities your wheelchair offers you and how these affect the driving behaviour and the driving safety.

Your dealer will be pleased to adjust your wheelchair to suit your individual needs in a way that takes all safety aspects into account.

Attention:

- ! Improper or incorrect adaptation, adjustment or assembly work means danger of accident!
- 🔧 Therefore, for your own safety:
Always have adaptation, adjustment and assembly work carried out by a dealer.

DRIVER TRAINING

For safe use of the wheelchair indoors and also especially outdoors an intensive driving training is necessary:

- Starting to drive,
- Steering,
- Braking while driving a straight course, in curves or backwards on level surfaces (if required with a helper).

Make yourself familiar with the driving behaviour of the wheelchair and slowly determine your limits. The wheelchair should not be used outside of the familiar environment or in public traffic before you have a safe control of the vehicle.

- ☞ Before the start of each journey
 - Check the function of the brakes.
 - Check the locking of the linchpin (quick-fit) axles (if fitted).
 - Check the Velcro fasteners of the seat and back support.
- ☞ Initially avoid uphill/downhill gradients [1], poor driving surfaces and similar [2].
 - Danger of accident!
- ☞ Always use the assistance of a helper or accompanying person to handle special driving situations, e.g. driving on gradients, poor road conditions, crossing obstacles.
- ☞ A danger of slipping always exists on wet, loose or unsuitable driving surfaces and the braking distance is usually longer.

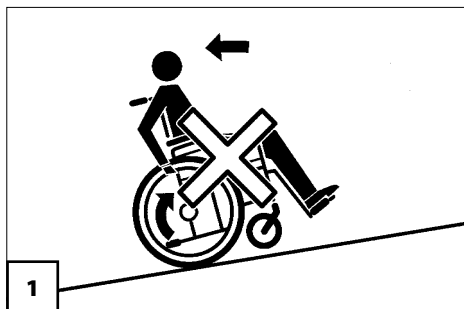

- ☞ Avoid a jerky vehicle movement during a transition from a rising/falling gradient to a horizontal surface, whilst driving a curve or crossing an obstacles.
- ☞ Always reduce the speed before a curve. A sharper curve requires a lower speed. Never lean outwards in a curve.
- ☞ Reduce the speed in difficult driving situations or tight spaces.
- ☞ Danger of slipping exists in winter and on a loose driving surface.

SUPPLEMENTAL USER INFORMATION

The following pages give general information and suggestions for the handling and use of the wheelchair in everyday situations. Make yourself thoroughly and carefully familiar with the wheelchair. New driving situations must be practised with the support of a helper.

- ☞ Always lock the brakes in order to prevent the wheelchair from moving before the transfer from/into the wheelchair.

Curve driving

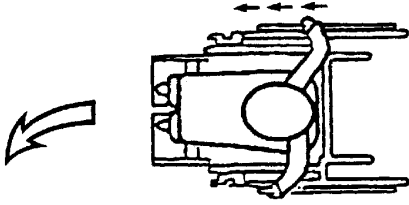

Turning

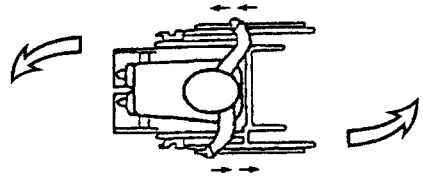

Turning on a slope

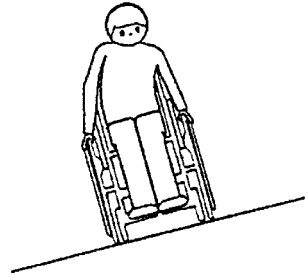

Driving downhill

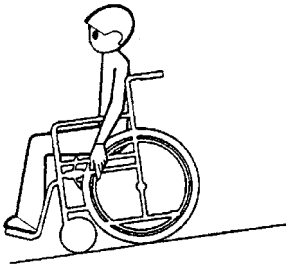

Driving uphill

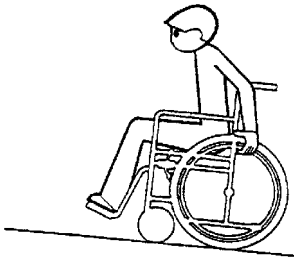

Approaching an obstacle

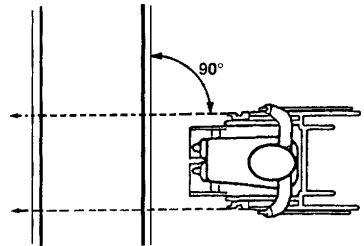

Obstacle crossing

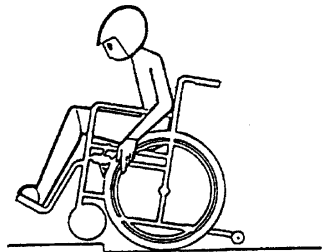

Crossing drops/steps

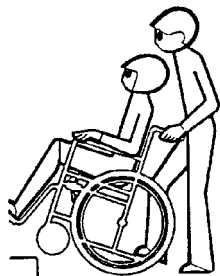
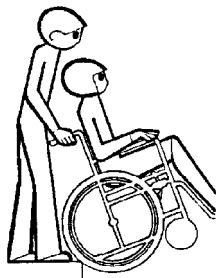

Steering wheels to the front = slight increase of the tilting stability

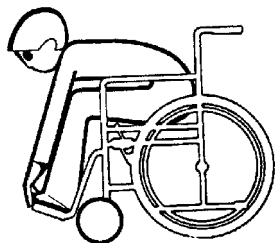

Attention:

- ! Before conducting the actions noted at the side generally activate the brakes.

Toilet use

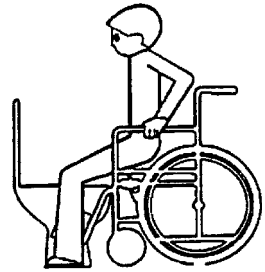
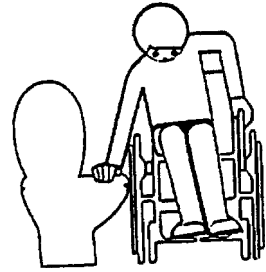

Transfer with sliding board

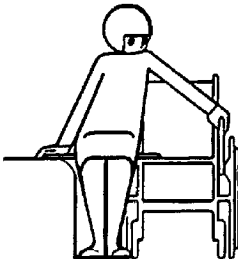
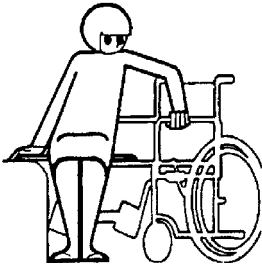

Transfer

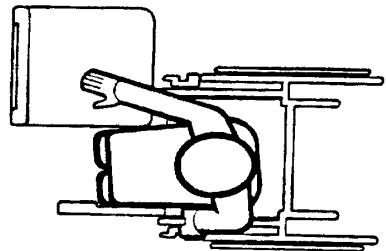
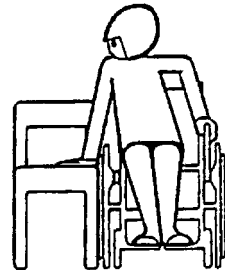

Wheelchair and car

Position the wheelchair parallel and adjacent to the driver's seat or front passenger seat. Detach the leg supports and the arm supports in order to reduce the wheelchair weight and make the lifting into the car easier. Lock the brakes to prevent the wheelchair from moving. The door frame can be used for holding or the seat for support during the transfer into the car.

A sliding board can be used to bridge the gap between the wheelchair and the car seat. The possibilities here depend on the type of vehicle, the height of the car seat and the height of the wheelchair seat.

Unlock the brakes of the wheelchair before its loading. The personal possibilities and the spaciousness of the vehicle determine whether the wheelchair is now pulled into the car from the driver's seat or the front passenger seat.

Two-door cars usually cause fewer problems because the doors are usually wider. In the case of a four-door car it may be necessary for a helper to lift the wheelchair into the passenger space or the boot.

Transfer into the car

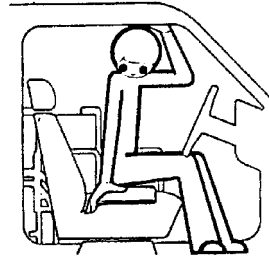
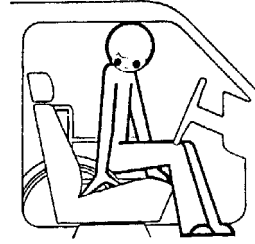

Loading the wheelchair

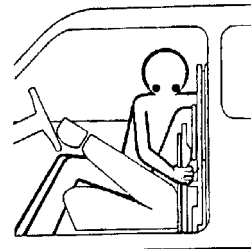
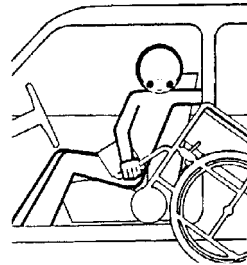

BRAKES

Check that the brake system works perfectly before the start of each journey!

In order to ensure the operational safety of your wheelchair use only authorised specialists for the adjustment, maintenance or subsequent fitting of the brake system!

As the brake system has two brake levers, both brakes must be operated simultaneously and equally for deceleration in order to prevent a course deviation.

Attention:

! If only one brake is applied when the wheelchair is driving down an incline, the free-running wheel will continue moving around the locked wheel.

☞ Depending on the gradient of the road, this can lead to the wheelchair overturning to the side.

The brakes have to be secured whenever interrupting the ride, when getting out or into the wheelchair and also when leaving the wheelchair, to avoid unintended rolling away.

Attention:

! Brake your wheelchair down very carefully when driving backwards.

☞ Abrupt braking with the handrims or the brakes can cause the wheelchair to tip over [1]!

- Prevent especially strong braking down of the wheelchair with the handrims.

☞ The thus created frictional heat between hand and handrim can cause injuries to the hand!

- Do not brake down the wheelchair with the feet when the leg supports are swivelled to the side or the footplates folded up.

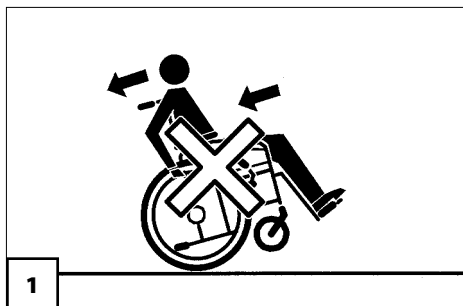

☞ Risk of injury by spraining the ankles!

Pressure Brake

The breaking force of the pressure brakes [1] (have direct effect on the tyres) could be limited resp. no longer guaranteed, in case of:

- worn brake pads,
 - tyre profile is worn
 - tyres are wet,
 - too little tyre pressure or
 - an amended axle position of the drive wheels.
- ☞ Wheelchairs with PU-tyres should be stored safely without activated pressure brakes in case of longer standing periods.
 - ☞ This can cause accidents during regular braking due to some occurring, remaining deformation in the surface.
 - ☞ In this case the wheelchair should be secured against rolling away, for example by removing the drive wheels.
 - ☞ Do not support yourself on the brake levers.
 - ☞ A loose brake lever mechanism reduces the braking effect.

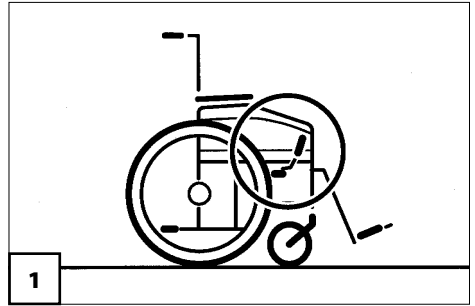

Drum Brake

A metered braking from driving speed (operating brake) is possible with the brake levers of the drum brakes.

The wheelchair is also to be secured against unintentionally rolling away (parking brake) by engaging these brakes.

Note:

The braking effect depends upon:

- the condition of the tyres,
- the condition and attachment of the brakes,
- the brake lever adjustment,
- the road condition.

Attention:

 The brake performance reduces with:

- – worn brake pads,
- loose brake lever,
- defective drum brakes.
- If the effect of the brake lessens immediately have them readjusted in a specialist workshop.

Drum brake for attendant

Locking the drum brakes

Pull both brake levers evenly to secure the wheelchair against unintentional rolling away.

Press the latch (1) forward.

Release the brake lever. – Depending on the adjustment the latch engages in the first (A) or second (B) locking position and activates the brake.

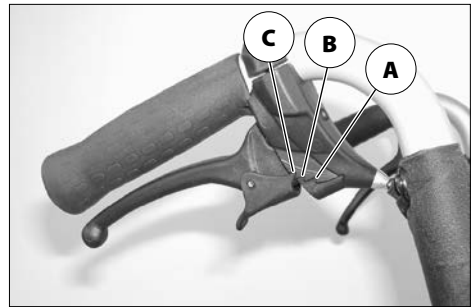
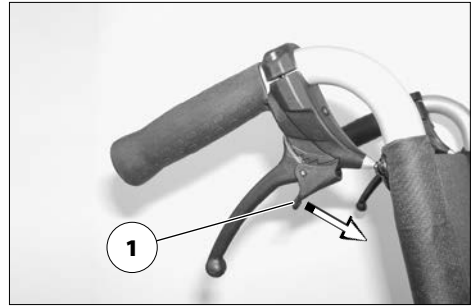

Note:

The wheelchair loaded with the user may not let itself be pushed in with the brakes engaged.

-  If the third locking position (C) is required to activate the brake, it must be readjusted by a specialist workshop.

Loosen the drum brakes

Pull both brake levers (1) until the latches (2) automatically jump out of the lock.

Let go of both brake levers. – The parking brakes are released and the wheelchair ready for use.

Attention:

! For operational readiness the brake levers must be disengaged.

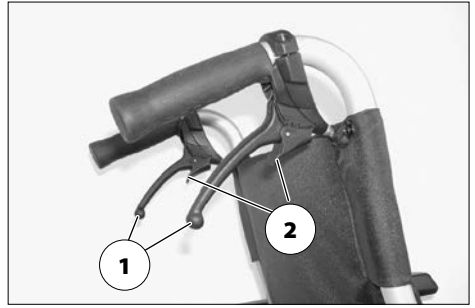

WEIGHT LOADING

Never load the wheelchair with excessive weight and never with more than one person!

Load benchmarks can be viewed in the technical data of the operating manual or on the type plate of the wheelchair.

TYRES

Tyres are made of a rubber mixture and can leave permanent or difficult-to-remove marks on some surfaces (e.g. plastic, wooden or parquet flooring, carpets, mats).

The braking effect of the pressure brakes depends on the tyre pressure of the drive wheels.

Tyre filling pressure

Check the pressure of your tyres regularly and before each journey! Low tyre pressure increases the tyre wear and decreases:

- the driving comfort,
- the driving safety,
- the service life of the tyres.

The tyre pressure values can be found in the operating manual of your wheelchair in section < *Technical data* >.

Never exceed the maximum permitted tyre pressure.

Practical information:

Pressing the tyre with the thumb will give you a rough indication of the tyre pressure.

If a suitable air pressure tester is not available or if there is no technical possibility, check the tyre pressure by pressing the tyre with your thumb. In doing so the tyre may not let itself be pressed inward significantly. In order to gauge the tyre pressure, take a seat inside the wheelchair and look at the bulge of the tyre where the tyre touches the surface. The tyre must be pumped up if the curvature is clearly noticeable. A hardly noticeable curvature means a sufficient air pressure.

Tyre condition

The tyres are subject to natural wear. Very worn or damaged tyres reduce the operational safety and must be replaced by your specialist workshop as soon as possible.

Note:

Always replace the tyres in pairs because tyres with different wear impair the straight-running of the wheelchair.

Tyre damage on pneumatic tyres

For repairing tyre damage we recommend the use of a foam cartridge that is available in speciality shops. – Afterwards look up a specialist workshop as soon as possible.

REMOVABLE DRIVE WHEELS

- ☞ Check the secure seating of the drive wheels after attachment [1].

The release pin for the loosening of the linchpin (quick-fit) axle must be in its home position again. i.e. protrude a few millimetres from the wheel nut [2].

Attention:

- ! Carry out a pull test after each attachment.

Check the cleanness of the locking pin / release pin. A functional fault may occur in the case of contamination due to sand or earth or in the event of freezing of moist cold air.

- ☞ The release pin is hidden behind a rubber cap on some models.

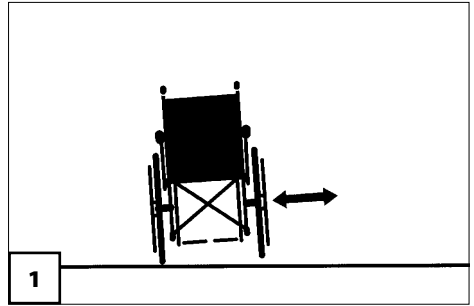

HEIGHT-ADJUSTABLE LEG SUPPORTS

When using a wheelchair with height-adjustable leg supports, you must take into account that a horizontal position of the leg supports and your legs displaces the centre of gravity forwards and consequently reduces the braking and steering performance and increases the danger of tipping over and the lateral drift of the wheelchair when driving transverse to a gradient.

Attention:

- ! The raised leg supports drop abruptly if the locking lever of the leg supports is accidentally operated [1] – Danger of injury!

FOOTPLATES

Rest your feet only on correctly individually adjusted foot plates. We recommend the use of calf straps with leg retaining belts, shoe belts and heel retainers. – Secure sitting position and non-slip foot position!

When the wheelchair does not bear your weight, e.g. during transfer from the wheelchair into bed, to the toilet or into the car or vice versa, you must never put your weight onto the foot plates [2] – Danger of accident! Unaided transfer is dangerous!

Attention:

- ! The foot plates are located in the leg area and can therefore cause tripping! Always fold up the foot plates and swivel away the leg supports before the transfer in order to have an unobstructed foot area [3].

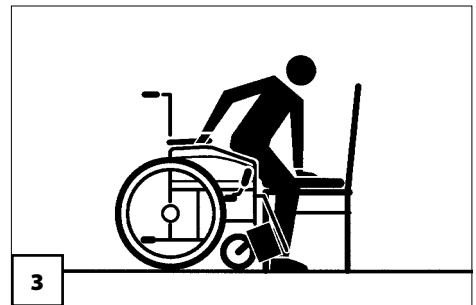
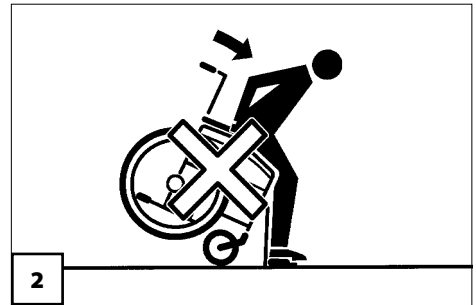
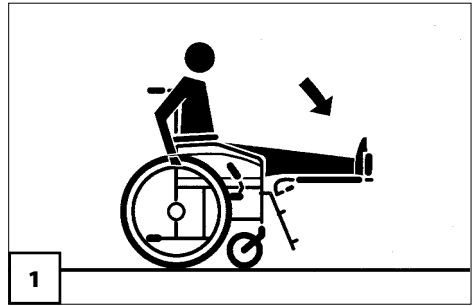

BACK SUPPORT WITH AN- GLE ADJUSTMENT

Wheelchairs with a reclining back support must have support castors (anti-tip castors) [1] or a wheelbase adapter.

A back support with a gas-pressure spring may only be reclined to the rear when the wheelchair is parked on an even and firm surface. For driving, the back support must be returned to the upright position.

Attention:

- ! A danger of tipping over exists when driving with a back support reclined to the rear!

SEAT ANGLE ADJUSTMENT

An extreme seat angle adjustment (wheel axle mounted in the upper area of the adjustable axle plate) increases the danger of tipping over during each journey and especially during uphill travel or the crossing of obstacles and reduces the ground clearance [2].

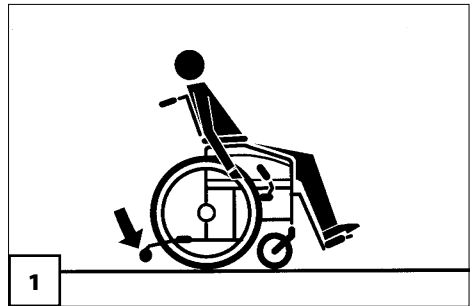

HANDRIMS

Take care that you do not squash your hands when driving narrow routes, e.g. building entrances, doorways, etc. [1]. – Danger of injury to the hands!

- Replace damaged handrims immediately in order to prevent your hands being injured by such handrims and in order to always have full control of your wheelchair.

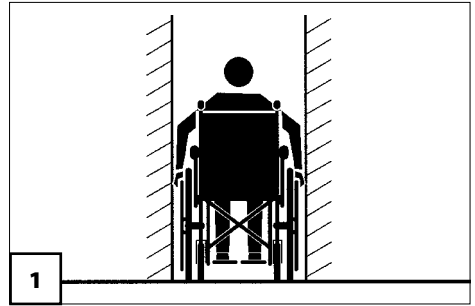

HEAD SUPPORT

If your wheelchair has an adjustable head support, ensure that the top edge of the head support is always positioned at the back of the head approximately at eye height [2].

Attention:

- ! Never at neck height!

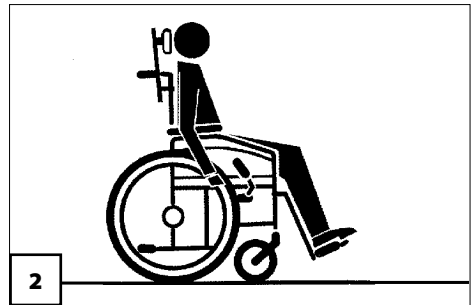

WALKING AID HOLDER

The walking aid holder serves to hold walking aids used with one arm and walking sticks and can also retrospectively be assembled by a specialist workshop.

Depending on the vehicle the walking aid is placed into the cup and fastened with the strap.

Attention:

- ! Have a defective band or defective cup replaced by a specialist workshop!
- Do not alienate the cup of the walking aid holder as an umbrella holder or transport bin!

RETAINING STRAP

The retaining strap serves to strap in a person sitting in the wheelchair.

- Additional stabilisation of the sitting position.
- Prevents the user from falling forwards out of the wheelchair.
- Continuous adjustment to suit the user's needs.

Attention:

! Make sure that no objects are trapped between belt and the body! – Thus you avoid painful pressure points.

🔧 Note:

The retrospective assembly of a retaining strap is only to be carried out by a specialist workshop!

Attention:

! The retaining strap is not part of the retaining system for the wheelchair and/or the driver during transport in motor vehicles.

Retaining strap with velcro fastener

Fastening the retaining strap with velcro fastener

Guide the end of the strap with the velcro hook-/loop strap (1) through the buckle (2), place them on top of each other in the desired position and close the velcro fastener.

🔧 Then carry out a pull test.

Opening the retaining strap with velcro fastener

For this open the velcro fastener and pull the end of the strap (1) through the buckle (2).

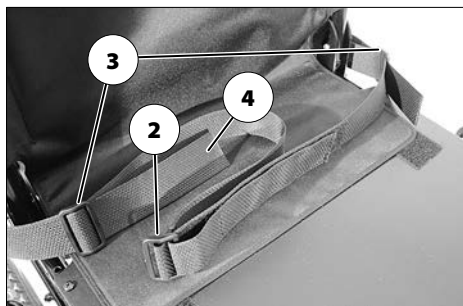

Adjustment of belt length

🔧 Note:

The retaining strap should not be pulled too tight.

The length of the retaining strap can be changed by sliding the strap buckle (3) and / or pulling the end of the strap (4).

Retaining strap with buckle

Fastening the retaining strap

Pull both belt halves to the front and slide the catch halves together so that they latch together [1].

☞ Then carry out a pull test.

Opening the retaining strap

Press the red release button (2) in the lock, resp. the spring parts of the latch (3) in order to open the retaining strap.

Adjustment of belt length

☞ Note:

The retaining strap should not be pulled too tight.

Depending on the version hold the buckle (3) or the latch (4) at a right angle to the strap (5).

Push or pull the strap (6) in the respective direction in order to extend or shorten the strap.

Shorten the loose strap ends (6) by moving the plastic slider (7).

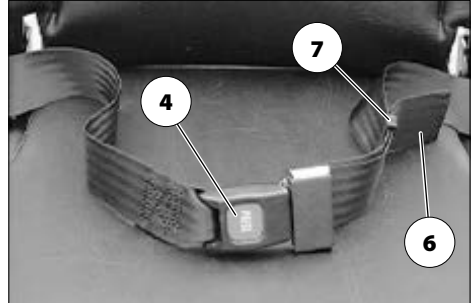
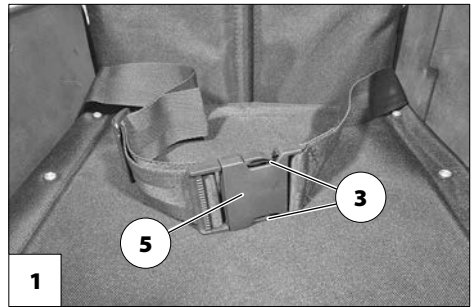
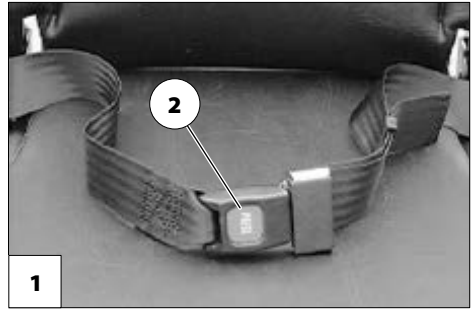

THERAPY TABLE

Attention:

- ! Place, adjust and reposition or remove the therapy table only after activating the brakes.
- Sharp objects (e.g. watches, rings, knives or belt buckles) as well as coarse dust can cause unattractive brush marks in the surface of the therapy table.
- Do not use aggressive or granular cleaning agents to clean the therapy table!
- Do not place any hot objects onto the therapy table!
- Do not drive with the therapy table attached when there are loose objects or containers with fluids on it!
- Do not use the therapy table as handle for carrying the wheelchair!



Mount the therapy table

The therapy table is pushed from the front over the arm support cushions [1].

Attention:

- ! For a safe stability of the inserted therapy table only arm supports with long arm support cushions should be applied.

TRANSFER OUT OF THE WHEELCHAIR

Unaided transfer is dangerous!

It requires;

- a great amount of body strength,
- good co-ordination,
- non-slip support (e.g. the palms of the hands on the seat of a chair, see [1],
- sufficient practice,
- knowledge of all possible danger instances.

Avoid accidents by using the assistance of a helper. Talk about the procedure and inform of foreseeable dangers, e.g. edges or curbs and also your type of handicap and use a sliding board if necessary.

Attention:

- ! Transferring into resp. out of the wheelchair may only be carried out with activated brakes.
- When the wheelchair does not bear your weight, e.g. during transfer from the vehicle into bed, to the toilet or into the car or vice versa, you must never put your weight onto the foot plates [2].
 - Danger of accident!
- The foot plates are located in the leg area and can therefore cause tripping! Always fold up the footplates and swivel away the leg supports before the transfer in order to have an unobstructed foot area [1].

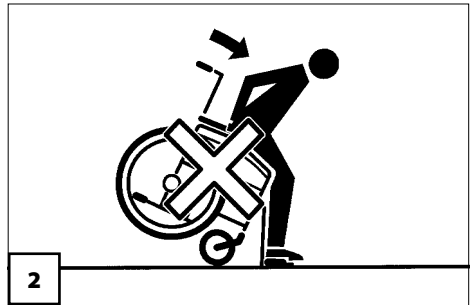
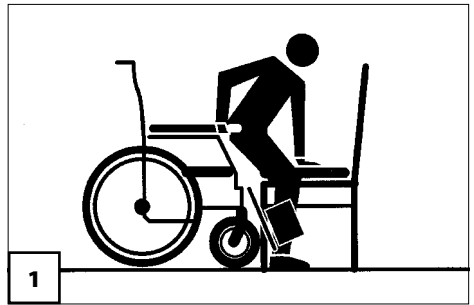

REACHING FOR OBJECTS

Avoid an extreme forward or backward inclination of the upper body when picking up or placing heavy objects [1]+[2]+[3]. – Danger of wheelchair tipping over, especially in the case of narrow seat widths and high seat heights (seat cushion)!

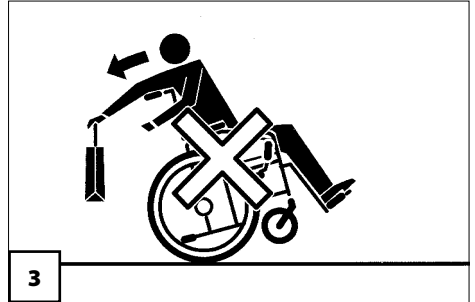
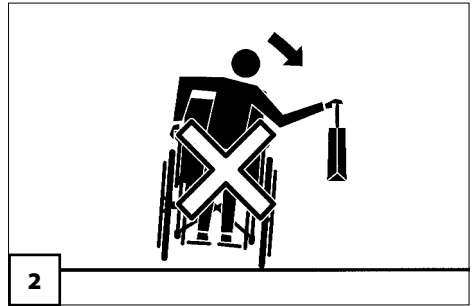
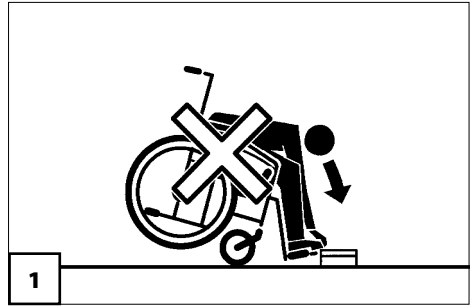

Correct procedure when reaching for objects [1]+[2]

Position the wheelchair as close as possible adjacent to the object.

Swivel the steering wheels (small wheels) to the front by turning the wheelchair. This increases the stability of the wheelchair.

Operate the parking brake.

Carefully pick up the object.

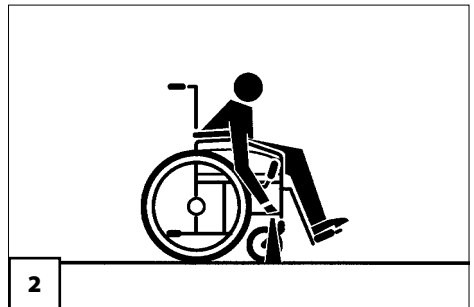
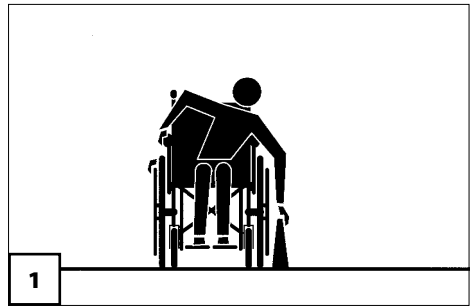

PROPELLING THE WHEELCHAIR

Use only the handrims on the drive wheels to propel your wheelchair.

Attention:

- ! Do not reach into the spokes or grip the tyres of the rotating wheels. – Danger of injury!
- Do not reach into the space between the pressure brake and the tyre when propelling the wheelchair. – Danger of injury!
- Avoid a jerky propulsion of your wheelchair [1].
 - ☞ Danger of tipping over or tilting!

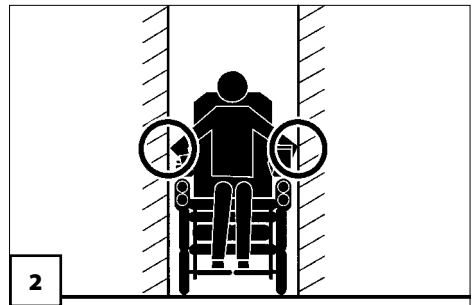
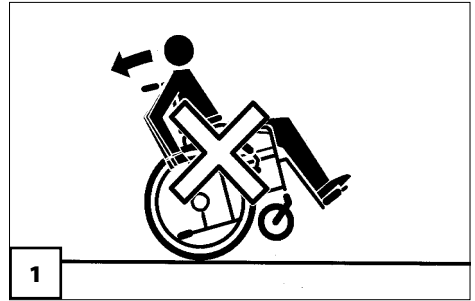

DRIVING THROUGH NARROW PASSAGES

When negotiating narrow spaces e.g. building entrances, doors etc., take care not to trap the lower arms. – Danger of injury to the lower arms [2].

DRIVING ON FALLING, RISING OR TRANSVERSE GRADIENTS

For safety reasons, the maximum permitted gradient is limited because the tip-over stability and the braking and steering behaviour are impaired by a reduced floor/road holding at higher gradient values.

- Information to the max. permitted inclinations can be found in the operating manual of your vehicle.

Do not lean towards the downhill direction when driving on rising, falling or transverse gradients.

Do not adjust the seat or back support angle on rising and falling gradients. – Danger of overturning!

While driving in curves and when turning on inclinations and slopes there is a danger of tilting.

Avoid jerky changes of the driving condition (especially with critically adjusted driving parameters as for example an active wheel position).

Uphill driving

The danger of tipping over increases with the steepness of the slope.

For your safety – we recommend that you use the assistance of an accompanying person – during uphill travel if the gradient exceeds 1 %* [1].

- This low gradient value is valid for persons that are not able to effect even the smallest centre of gravity change by changing the position of their upper body.

The stability of a vehicle is significantly reduced when driving on a rising gradient.

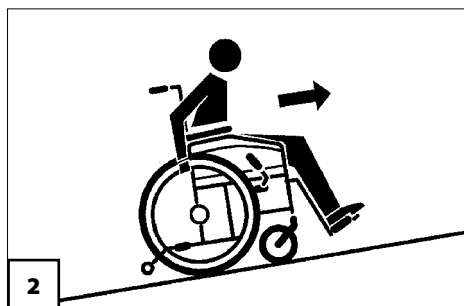
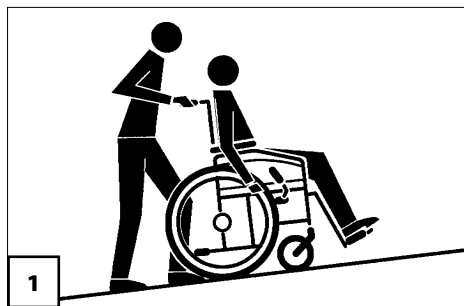

- Danger of tipping over.

Use supporting castors (anti-tip castors) and lean your body forward [2].

- Reduces the danger of tipping over!
- We recommend the fitting of a wheel-base extension to the wheelchair:
 - in the case of a leg amputation,
 - in the case of a reclining back support,
 - to increase the stability.

When driving uphill, refrain from [3]:

- a jerky starting,
- the transport of items in containers behind the back support,
- extreme rearward inclination of the upper body.

Be aware that a raised sitting position (e.g. due to a seat cushion) and in the case of active wheelchairs a greater seat tilt (due to a driving wheel axle position in the upper area of the adjustable axle plate) negatively influences the centre of gravity point and increases the danger of tipping over.

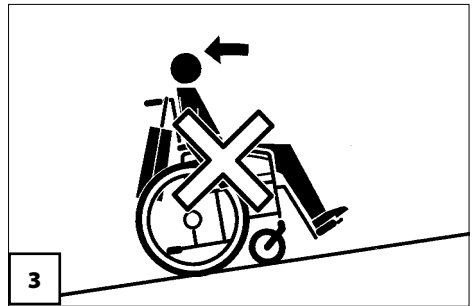

Downhill driving

For your safety, we recommend that you use the assistance of an accompanying person for downhill travel in the same way as described for uphill travel [1].

- ☞ When driving downhill observe the indication on the type plate.

The accompanying person should be aware that the control of the wheelchair requires more strength on a downward slope than on a level driving surface and that there is an increased danger of slipping.

- ☞ Driving downhill without a helper must be done very carefully!
- ☞ Never drive faster than walking speed! Never drive backwards!

You must have your wheelchair under control at all times during the downhill travel!

Incline your upper body slightly to the rear in order to maintain the driving stability.

- ☞ Never slide forwards in your wheelchair.

Attention:

- ! The braking force transferred to the driving surface is much less on a downward slope than on a level driving surface and is further reduced by poor road conditions (e.g. rain, snow, grit, dirt). A dangerous slipping of the wheels due to excessive braking and an associated unwanted course deviation must be avoided by way of a careful dosed braking.

At the end of the downward slope, take care that the foot plates do not make contact with the ground and endanger you through a sudden braking effect [2].

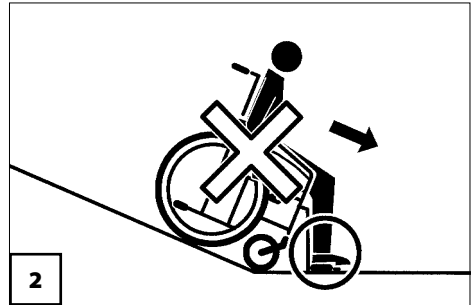
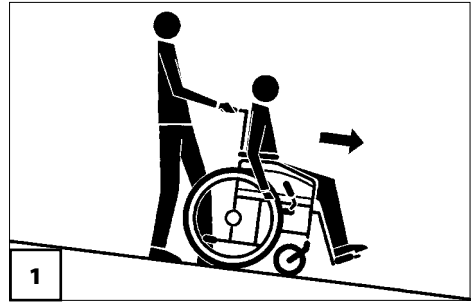

Driving transverse to the inclination

We also recommend the support of an accompanying person in this driving situation.

- ☞ Driving transverse to a slope without a helper must be done very carefully!

Do not lean out of the wheelchair in the downhill direction!

Never drive backwards!

Slopes transverse to the driving direction (e.g. transversely sloped pavements) effect a turning of your wheelchair in the downhill direction. You or an accompanying person must compensate for this drift by a counter-steering [1].

TURNING DURING UP-HILL/DOWNHILL DRIVING

Should you need to turn on a slope, be aware that the driving behaviour of your wheelchair has changes.

- ☞ Follow the safety information of the thus occurring driving situations [1]:
 - Uphill driving on page 30
 - Driving transverse to the inclination on page 33
 - Downhill driving on page 32

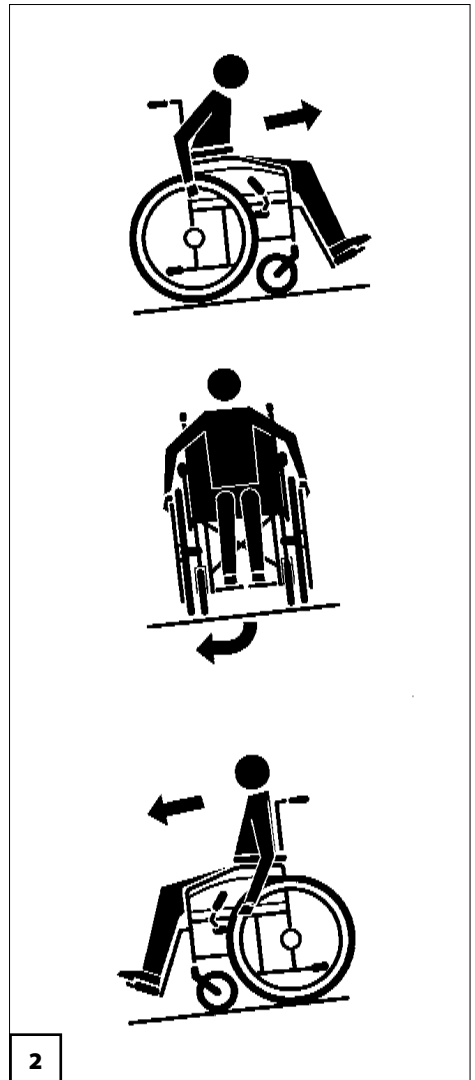
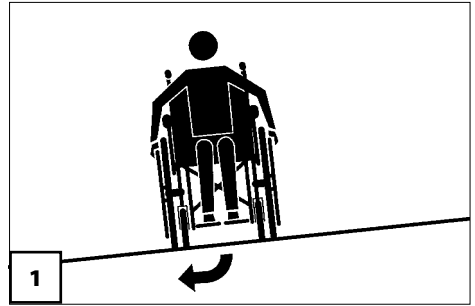

ANTI-TIP CASTORS AND WHEELBASE ADAPTER

The fitting of rear-pointing anti-tip castors and wheelbase adapters results in a higher stability against tipping due to the longer wheelbase and therefore in additional safety. These parts are available as accessories and are recommendable, respectively necessary, in the following cases:

- when carpet edges, sills, small steps or similar obstacles must be crossed in the indoor use environment.
- when the wheelchair is used outside of the accustomed environment. Poor driving surface conditions must always be expected here.
- When the physical and psychological possibilities of the user do not permit or limit an active driving behaviour, i.e. a displacement of the centre of gravity by way of movement or body posture and in the case of users with amputations in the leg area.
- first-users and inexperienced wheelchair users.
- when a reclining back support is used.
- after wheelchair modification/adjustment that influence the driving behaviour (position of the wheels and back support).

Attention:

- ! Support castors do not provide sufficient protection against tipping over in certain situations.

Therefore, do not:

Leaning the upper body far back.

Start off abruptly, especially when driving uphill.

When the centre of gravity shifts due to repositioning of the driving wheels (small axle distance).

For your own safety, use the assistance of an accompanying person in the following potentially dangerous situations:

- transferring from a non-solid to a solid driving surface, e.g. grass verges, soft verges.
- Driving on roads with tram lines.
- Driving over gully covers with long holes pointing in the driving direction.

Correct support wheel length:

The support wheel has to extend beyond the driving wheel in order to provide sufficient support.

For sufficient tilting stability both support castors (if available) are to be positioned parallel. – Danger of accident by overturning to the side!

CROSSING OBSTACLES

Each crossing of obstacles involves a risk! Even flat obstacles (e.g. sills, carpet edges, small steps or similar) represent a danger of tipping.

The crossing of obstacles is a special danger situation in which a combination of the safety advice in the sections headed uphill driving, downhill driving and driving transverse to a slope must be observed in addition to other safety advice.

For your own safety, obstacles like

- grass verges
- tram lines
- gully cover or similar

should only be driven over with an accompanying person [1]!

- ☞ The unassisted, safe, crossing of small obstacles is only possible with a sufficiently safe control of the wheelchair.
- ☞ Always approach small obstacles, e.g. steps or curbs, slowly and at a right angle (90°) until the steering wheels almost touch the obstacle. Briefly stop the wheelchair and then drive over the obstacle.
- ☞ Always drive over an obstacle forwards (not backwards) and simultaneously with both front/rear wheels in order to prevent a sideways tipping of the wheelchair.
 - Incline your upper body slightly forwards to displace the weight when crossing the obstacle.
- ☞ Always maintain a safety distance between the wheelchair and drops, stairs and similar obstacles sufficient for reaction, braking and turning.

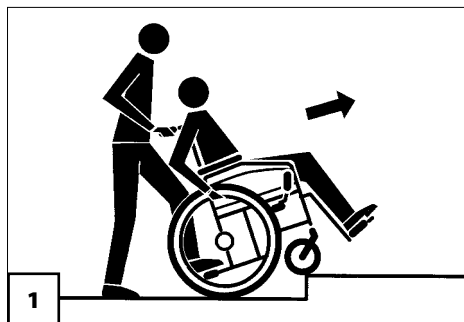

The obstacle crossing capability depends on the driving surface gradients, the adjustment of the leg supports and body position.

- ☞ Incline your upper body slightly forwards to displace your weight.

Ask your wheelchair dealer about the maximum crossable obstacle height for your individually adjusted wheelchair.

For safety reasons, we must point out below that the obstacle crossing capability of wheelchairs is very limited.

This limit is:

- 11 mm for active wheelchairs
- 24 mm for standard wheelchairs.
- ☞ This low obstacle crossing capability value is based on the assumption that you are not able to effect even the smallest centre of gravity change by way of moving your upper body.

Attention:

- An especially large danger of the wheelchair tipping over exists if the drive wheels make contact with the edge of the obstacle [2].
- When driving down a step (e.g. pavement edge), you can easily fall out of the wheelchair if the foot plates or leg supports land on the driving surface [3]. Use the assistance of a helper in case of doubt.

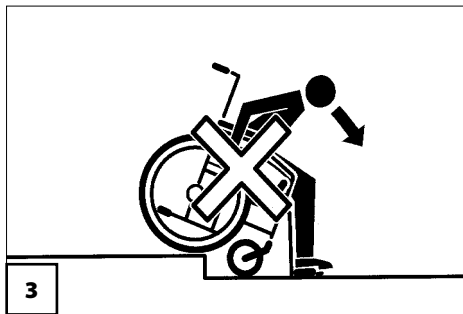
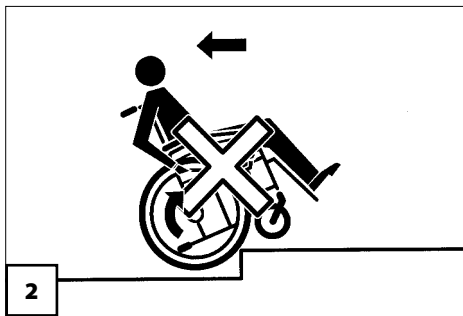

Anti-tip castors can endanger the obstacle crossing. The drive wheels can lose their contact with the driving surface when the wheelchair is carried by the anti-tip castors [4].

- ☞ The driving ability is encumbered.

You must not let yourself be carried in your wheelchair through the lifting of the wheelchair. Parts that are not securely fixed, e.g. side elements or leg supports, can come away and thus cause an accident.

- ☞ The wheelchair is a vehicle and not a carrying device.

If possible, let one or more helpers lift you out of the wheelchair and carry you to the destination point [5]+[6].

- ☞ Activate the parking brake priorly to prevent unintentional rolling off [6].

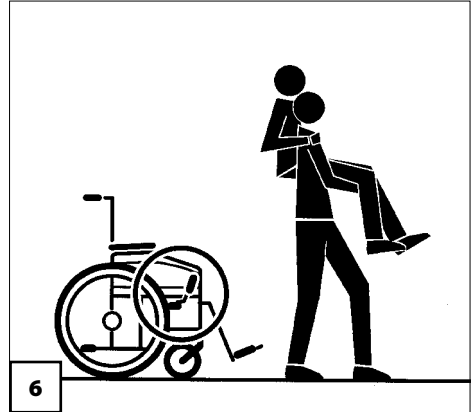
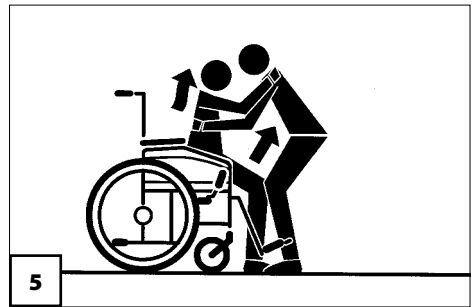
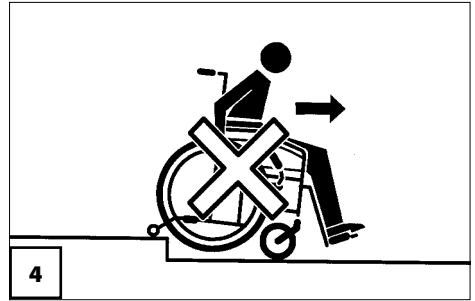

The crossing of stairs is only possible with the assistance of two helpers who are familiar with the danger situation and firmly guide the wheelchair.

- ☞ The helpers may only hold (without lifting) the wheelchair with the push handles and the side frame.

Attention:

- ! Do not lift the wheelchair with the side elements/arm supports or leg supports!

Anti-tip castors (if fitted to the model) should be swivelled out of the way or removed because they impede the transporting [7]+[8].

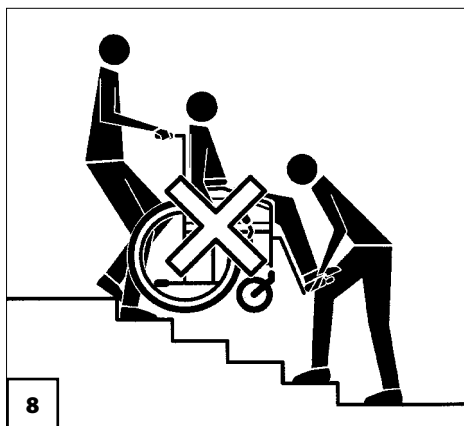

WHEELCHAIR FOLDING/ UNFOLDING/CARRYING

Folding the wheelchair

Your wheelchair can be folded in a few moments without tools being required [1].

- Remove the seat cushion, if applicable.
- Remove the calf belt if necessary.
- Lift up the footplates or remove the leg supports.
- Bend the back belt to the rear.
- Pull the seat belt upward in the centre of the front and back.

Carrying the wheelchair

Your wheelchair can be carried without difficulty when folded.

- From the front push one lower arm under the upward folded seat belt.
- Place other hand underneath the rear seat fold for support.

Lift the wheelchair to horizontal position.

Unfolding the wheelchair

Tip the wheelchair slightly to one side in order to make the unfolding easier. At the side resting on the floor, press the seat tube down to the end stop [2].

Note:

You may need to press down both seat tubes with the hands in order to do this.

-  Ensure that the seat tube sits securely on the support surface.

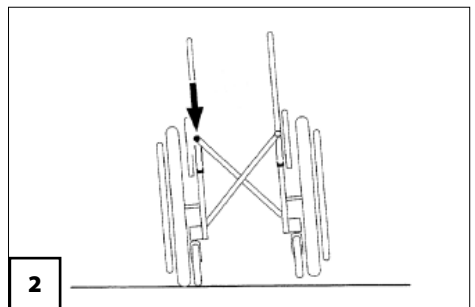

TRANSPORT IN MOTOR VEHICLES OR WITH CONVEYORS

Secure your unoccupied wheelchair so that it does not present additional danger during dangerous driving manoeuvres of the transport vehicle.

Never use a conveying device that is not approved for the conveying of wheelchairs with a passenger sitting inside. Floating transport is not permitted! – Danger of accident!

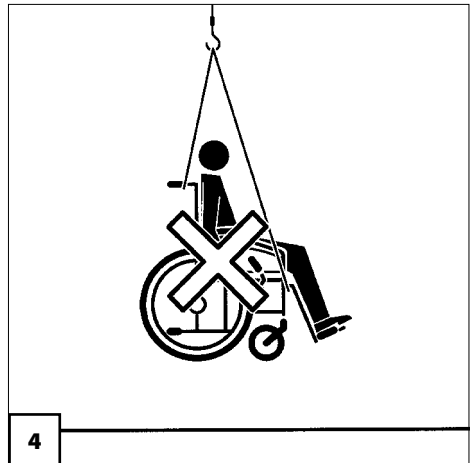

Transport safety of the empty wheelchair

- ☞ For this the regulations of the respective transport company are to be observed.

Carry out the following steps when the wheelchair is located in the transport vehicle:

1. Operate parking brakes.
 - ☞ view < *Operating manual* >.
2. Stow all disassembled wheelchair parts in a secure and protected way.
3. Remove bags, walking sticks and other items not belonging to the wheelchair and stow these safely.
4. Secure the wheelchair by way of elastically fastened straps.
 - ☞ Only attach the fastening straps to designated parts of the car and wheelchair.
 - ☞ The anchor points of your wheelchair are each marked with the symbol (1).
 - ☞ Please look up the positions of the anchor points in the operating manual of your wheelchair.

Attention:

- ! Changes on the wheelchair and especially the anchor points may not be made.
- Do not use the side elements, footplates or push bar to rig the wheelchair
- Only use permitted fastening material.
- ☞ Suited brackets are described in the operating manual of the transportation vehicle.

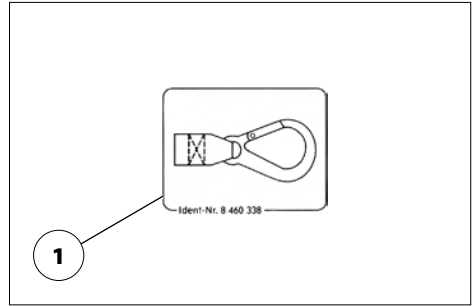

Transport in vehicles

The following procedures may be necessary due to lack of space for the transport in vehicles:

- Remove the leg supports.
- Remove the arm supports.
- Remove or fold over the back support.
- Detach drive wheels

The parts detached for the transport must be carefully stowed and carefully attached again before the next journey!

Note:

During reassembly, ensure that each part is correctly installed and securely fastened. Check that components are correctly positioned.

-  Check the correct seating of the components.

Attention:

-  Do not use the wheelchair without attached leg supports and arm support units!

Transport of people inside a motor vehicle

To determine if your wheelchair is approved as a seat for person transport inside a motor vehicle, please look at the type plate of your wheelchair.

Note:

Wheelchairs that are not suited for use as a seat for transport in a motor vehicle are marked with an additional label.

– For this view chapter < *Bedeutung der Klebeschilder auf dem Rollstuhl* > in the operating manual.

-  Observe the guideline < *Safety with Meyra-wheelchairs, also during transport in motor vehicles* >! – This document and further information are available in the < *Infozentrum* > on our website < www.meyra.com >

DRIVING ON RAMPS, ELEVATORS AND LIFTING PLATFORMS

Ramps, lifts and lifting platforms are a special danger for wheelchair drivers.

Attention:

- ! Do not drive on ramps, lifts or lifting platforms without side protection!
- Danger of injury to the hands from automatically closing doors!

Get an accompanying person to push your wheelchair onto the lifting platform if there is a danger of falling.

- 🚫 Secure the wheelchair against unintentional rolling motions!

Attention:

- ! Ensure sufficient safety distance to possible danger areas [1].
- Never drive on escalators with the wheelchair. – Danger of accident!

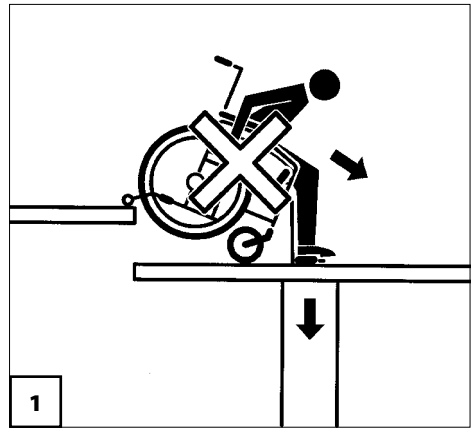

Ramps and lifting platforms

When the wheelchair is loaded with the help of ramps or lifting platforms, the following safety information are to be observed:

- The operating manual for the transport vehicle.
- The manufacturer's information for the ramp or lifting platform.

Attention:

- ! The maximum bearing height specified for the ramp must be greater than the height 'h' from the ground to the loading surface, e.g. of the car.

Ramp version

1. A parted ramp (1) consists of a minimum of two slim, transportable driving tracks.
2. A one-piece ramp consists of one wide transportable driving track.
3. A firm ramp consists of one wide driving track that is connected firmly with the surface.

The wheelchair can, if required, be driven into the transport vehicle over ramps with own propulsion power.

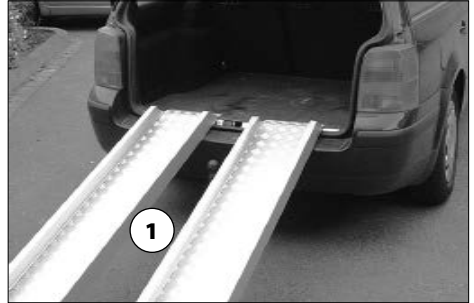
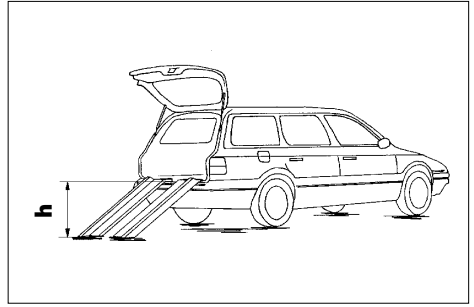

Special safety information

For safety reasons, the wheelchair must be unloaded (without baggage and without user) during its loading into a car or when a split ramp is used.

Park the car or van on level and firm ground and engage the brake in order to prevent the vehicle from moving.

Ensure that the ramp cannot slip at the ground end or at the transport vehicle end.

Ramps should be positioned so as to leave enough space for wheelchair steering correction without one of the wheels protruding over the edge of the ramp.

Only use the wheelchair on dry, clean and undamaged ramps or lifting equipment.

Only approved ramps or lifting platforms may be applied (view type plate).

Attention:

- ! The loading capacity per ramp or lifting equipment must be for the wheelchair:
 - without driver above the permitted user weight, deducted the user weight and
 - greater than the permitted overall weight with driver (fixed ramp)!
- 📖 The permitted overall weight and user weight of the electric vehicle can be found in the < *Technical data* > of the operating manuals.

TRANSPORT IN PUBLIC METHODS OF TRANSPORTATION

Parking space

The space reserved for parking is marked with symbol [1].

User information

Park your wheelchair opposite to the driving direction in the reserved space.

The wheelchair is to be placed so that the back support it will be supported by the border of the parking space.

One side of the wheelchair must also lie against the border of the parking space, so that the wheelchair cannot slide away in case of an accident or sudden braking manoeuvre.

 **Note:**
Additionally activate the parking brakes.







DRIVING ON PUBLIC HIGHWAYS

In Germany you are subject to the German laws for traffic regulation (Strassenverkehrsordnung (StVO)) as a pedestrian.

With limited visibility and especially in the dark we recommend to mount active lighting equipment and to turn it on in order to see better and be seen [1].

Note:

- When participating in public traffic the user is responsible for the functional- and operationally safe condition of the wheelchair.
-  The valid traffic regulations must be observed and abided when participating in public traffic.
-  Wear light-coloured and conspicuous clothing when driving in darkness.
-  When driving in the dark avoid using the road or bicycle lanes.
-  Ensure that the vehicle headlights, indicators, rear lights and reflectors are not covered by clothing or by items secured to the vehicle.

Adapt your driving behaviour outdoors to the weather and road conditions.

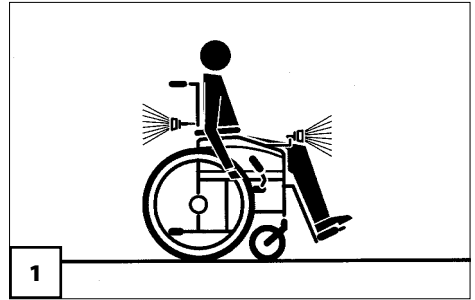

ROAD AND WEATHER CONDITIONS

One of the drive wheels can lose its contact with the driving surface when driving on an uneven driving surface. This can cause a change in direction of the wheelchair.

- ☞ Therefore avoid uneven driving surfaces.

Using the wheelchair on slippery surfaces (e.g. ice, snow, wet leaves, sand on asphalt) or on a slope can result in a dangerous situation.

- ☞ Danger of uncontrollable skidding.

Attention:

- ! Take special care when using the wheelchair on slippery surfaces. – Danger of accident!
- ☞ When parking outdoors protect the wheelchair against dampness with a plastic cover (accessories) [1].

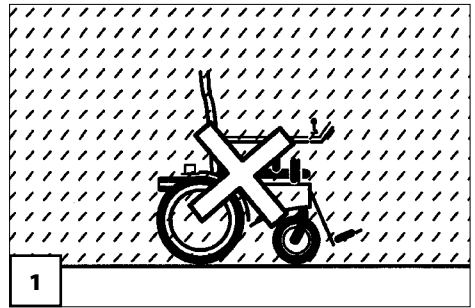

ACCOMPANYING PERSON

The accompanying person must be made aware of all possible danger situation before the start of his/her supportive involvement. The parts of your wheelchair that are held onto by the accompanying person are to be checked for tight fit.

ADDITIONAL INFORMATION FOR FOLDING WHEELCHAIRS WITH LEVER DRIVE

Objects must not be secured to, carried by or come into the swivel area of the drive levers. – Danger of accident!

Have the position of the hand levers set by an authorised dealer. – They have a large influence on the driving safety.

AUXILIARY DRIVES

The attachment of additional and header drives constitutes a considerable amendment to the wheelchair, with the consequence that the declaration of conformity of the wheelchair expires.

- ✎ The verification of conformity in combination with the directive 93/42/EG lies in the responsibility of the supplier of the additional or header drive. He is also responsible for the product included documentation of the medical product combination.

SERVICE

As any other technical product, the wheelchair also requires regular care and maintenance. The following care instructions and the maintenance manual describe the measures that are to be carried out so that the wheelchair provides the following advantages even after a longer period of use:

- the safety for you and others,
- the operational readiness,
- the value conservation.

An incorrect or neglected cleaning and maintenance of the wheelchair results in a limitation of the product liability.

Information for the specialist dealer

Maintenance and Service manuals can be retrieved from our website < www.meyra.com >. You can for example find the following information in these manuals:

1. Adjustments that can be carried out with tools.
2. Step by step explanations to important repairs.
3. Information on model specific amendments.
4. A checklist for the annual inspection.

The functional tests necessary for the inspection are listed in the check list.

They are a guide for the performance of the inspection work.

Note:

It does not outline the actual scope of the necessary work which can only be ascertained by an inspection of the vehicle.

After the successful completion of an annual inspection the inspection certificate should be recorded in the operating manual.

A draft for further inspection certificates can be copied from the maintenance and service manual when required. It then has to be added to the operating manual.

Information for extended pauses of use

No special measures are required during extended pauses of use.

-  Observe the storage temperature noted in the < *Technical Data* > of the operating manual of your wheelchair.

Tyres

A difference in tyre pressure between the wheels on one axle causes the wheelchair to pull to one side and makes straight-on driving difficult.

- ☞ Too low tyre pressure increases the rolling resistance and requires more energy to propel the wheelchair.

Always inflate the tyres to the max. permitted tyre pressure but never exceed the max. permitted tyre pressure.

- ☞ But never exceed the max. permitted tyre pressure.

Check the tyres regularly for following issues:

- ☞ Tyre pressure view chapter < *Technical data* > in the operating manual.
- ☞ That the tyre valves are always protected against dust with the valve caps.
- ☞ Tread/condition.
 - ☞ Worn tread impairs the driving behaviour.
- ☞ In case of a change of tyres, always exchange the tyres in pairs.

Cleaning and maintenance

Keep the lighting components clean at all times and check for correct functioning before each journey.

Do not clean the wheelchair with a high-pressure cleaner!

Silicone free water based cleaning agents and care products should be used for the care of the vehicle.

- ☞ In doing so the manufacturers instructions are to be observed.
- ☞ Do not use aggressive cleaning agents e.g. solvents, or hard brushes etc.

Upholstery and covers

The cushions and covers are normally fit with care instructions (instruction for care). In all other cases the following information is true:

- Clean the upholstery with warm water and hand washing liquid.
- Remove spots with a sponge or a soft brush.

Note:

Wash off persistent dirt with commercial fine detergent.

-  Do not soak! Do not machine wash!

Follow-up with clean water and allow to dry.

Chassis

The chassis and wheels can be cleaned damp with a mild detergent. Afterwards dry off well.

Note:

Check the chassis for corrosion damages as well as other damages.

Occasional application of a light cover of oil to all moving parts (see also Maintenance Instructions) will ensure that your wheelchair will give you many years of service

Plastic parts

The plastic panels and parts are made of high-quality plastic.

-  Only clean the plastic parts with warm water and neutral detergent or soft soap.



Attention:

-  The plastic panelling is attacked through non-ionic tensides as well as solvents and especially alcohol.

When using commercial plastic cleansers the manufacturers application instructions are to be observed.

Finish

The high quality finish ensures an optimum of protection against corrosion.

-  For paint and chrome care the commercially available brand name paint and chrome cleansers are recommendable.
-  Should the coating be damaged with scratches or similar, these areas can be touched up with our paint pen available at the specialist dealer.

Slight lubrication of moving parts will ensure for their long functioning.

-  View chapter < *Maintenance* > in the operating manual.

Disinfection

If the product is used by more than one person (for example in a care centre), the use of a commercial disinfectant is mandatory.

- ☞ Before disinfection the upholstery and handles are to be cleaned.
- ☞ A spray- or wiping disinfection is permitted with tested and accredited disinfectants.

A list of the disinfectants and disinfection means tested and approved by the Robert Koch Institute can be found under:

< <http://www.rki.de> >.

- ☞ During the use of disinfectants it can happen that surfaces might be affected in such a fashion that the long term functionality of parts can be limited.
- ☞ In doing so the manufacturers instructions are to be observed.

Reinstallation

Before reimplementation the wheelchair is to undergo a complete inspection.

☞ **Note:**

- The hygienic measures required for reinstallation are to be carried out in correspondence with the validated hygienic plan.
- ☞ Should your specialist dealer carry out a revision/reconditioning or make fundamental changes to your wheelchair, without the use of original spare parts, this under certain conditions may result in a remarketing of your wheelchair. This will further entail that your specialist dealer might need to conduct new conformity assessments and tests.

Repairs

Trustfully contact your local specialist dealer or another specialist workshop for carrying out repairs. They are briefed in carrying out the work and have educated personnel.

Customer Service

In case you have questions or require help, please contact your local specialist dealer, who will provide counselling, customer service and repairs.

Spare parts

Spare parts can only be ordered from specialist dealers. In case of repair work, only original spare parts are to be used!

Note:

Spare parts from other manufacturers can cause malfunctions.

The spare parts list with the respective part numbers and drawings is available at the specialist dealer.

Attention:

 Safety relevant parts or assembly groups are only to be assembled in a specialist workshop. – Danger of accident!

In order to ensure the correct delivery of a spare part, always quote the corresponding serial number (SN) of the wheelchair! You will find this on the type plate.

Whenever a wheelchair change/modification is carried out by the specialist dealer, the supplementary information, e.g. assembly/operating instructions must be attached to the operating manual for the wheelchair, the date of the modification must be recorded and stated when ordering spare parts.

This should prevent wrong order details on future spare parts orders.

Disposal

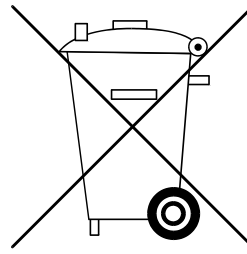

The disposal must comply with the respective national law.

Please enquire about local disposal arrangements at your municipal authority.

The vehicle packing material can be disposed of as recyclable material.

The metal parts can be disposed of as recyclable scrap metal.

The plastic parts can be disposed of as recyclable plastic.

Electrical parts (such as external lighting) can be disposed of as electronic waste.

NOTES

Your specialist dealer

MEYRA GmbH



Meyra-Ring 2
D-32689 Kalletal-Kalldorf



Tel +49 5733 922 - 311
Fax +49 5733 922 - 9311



info@meyra.de

www.meyra.de
